

CASE IH
AGRICULTURE
FOR THOSE WHO DEMAND MORE

OPTUM CVXDRIVE

250 - 300 HP TRACTORS



THE OPTUM CVXDRIVE

Another Milestone for Case IH.

Case IH has always been focused on customer requirements in the agriculture industry. Customers have told us that they need a tractor with more power close to ‚Puma‘ dimensions for their unique applications. Our solution is the Optum CVXDrive range, which will become another milestone in the Case IH product history.

This range is powerful, compact and highly manoeuvrable with excellent power-to-weight-ratio. With it's stunning new design and eye catching signature lighting this tractor will handle any given task with maximum performance, efficiency and reliability.

THE OPTUM CVXDRIVE. THE OPTIMAL SOLUTION.







THE BEST OF BOTH WORLDS

Heavy-duty performance. Compact design.



With its sleek looks and comfortable ride, it confidently outputs between 250 to 300 rated horsepower, depending on the model. The optimal power-to-weight ratio provides even greater versatility and opens up wider working windows in every situation.

Whether its tillage, seedbed preparation, planting, or haulage during harvest, we have equipped the Optum CVXDrive with the latest systems to ensure maximum traction in

the field and efficient handling and braking on the road. The Optum CVXDrive offers impressive control and safety. It feels great to drive, and we are certain you will enjoy the satisfying feeling of driving the most profitable investment around.

THE OPTUM CVXDRIVE. OPTIMAL EFFICIENCY.

TECHNOLOGICALLY ADVANCED

With the Case IH Advanced Farming Systems (AFS™), you can choose from a full range of guidance solutions offering accuracy levels of up to 1.5 cm. The AFS Pro 700™ monitor allows you to maintain control at any time – for example with the HMC II (Headland Management Control II) and it can maximise your efficiency, when operating ISOBUS Class III-compatible devices.

THE TOP PERFORMER

Productivity for all applications.

For a tractor of this size, the efficient power provided is breathtakingly impressive. You can rely on the smooth, no-compromise delivery of power as the engine effortlessly lugs any primary tillage implement, and hauls large trailers economically and safely at up to 50 km/h on the road.

THE OPTUM CVXDRIVE. OPTIMAL PRODUCTIVITY.

COMFORTABLE RIDE

The front axle provides two damping cylinders with 110 mm travel and is saddle mounted to the engine sump. An adaptive control logic is used to ensure high performance, comfort and stability.

MODELS	Rated power ECE R120 ¹⁾ @ 2,100 rpm (kW/hp(CV))	Maximum power ECE R120 ¹⁾ @ 1,800 rpm (kW/hp(CV))	Max. pump flow rate Standard / Optional (l/min)	Max. lift capacity through range [kg]
Optum 250 CVXDrive	184 / 250	201 / 273	165 / -	11,058
Optum 270 CVXDrive	199 / 271	212 / 288	165 / 220	11,058
Optum 300 CVXDrive	221 / 300	230 / 313	165 / 220	11,058

¹⁾ECE R120 correspond to ISO 14396 and 97 / 68 / EC





EFFICIENT AND PROVEN ENGINE

The new powerful 6.7 litre, 6-cylinder engine is designed to generate power and optimise fuel efficiency. Stage V emissions standards are achieved with our proprietary high efficiency Hi-eSCR2 after-treatment system.

STEPLESS PRODUCTIVITY WITH CVXDRIVE

The CVXDrive continuously variable transmission allows stepless travel from 0 to 50 km/h ECO.

LIGHT AND POWERFUL

The engine sump design is the backbone of the tractor. This compact design minimises weight to allow a 16,800 kg gross vehicle weight and an excellent payload of up to 6,300 kg. It enables the customer to add ballast when needed or use heavy front and rear implements.

ENHANCED SAFETY

The Optum CVXDrive outputs very high power for its low weight and is capable of travelling at high speed with heavy loads on the road. To enhancing safety, an Advanced Trailer Brake System and ABS is available and will provide operators with much greater peace of mind when working with heavy trailed equipment in difficult conditions.

A GREAT DAY AT WORK

The great feeling of driving Case IH's Optum CVXDrive.

Experience the supreme level of comfort offered by the Optum CVXDrive. Not only is it easy to use but it also looks great and is a joy to drive.

THE OPTUM CVXDRIVE. OPTIMAL DRIVING.







- A** Left-hand cab storage area
- B** Instructional seat
- C** Luxury carpeted floor reduces noise levels from transmission/drivetrain
- D** Heated and ventilated seat with extendable/retractable lower seat cushion
- E** AFS PRO 700™ Touch screen
- F** Multicontroller armrest
- G** Auto climate control

A

B

C

D

F

E

G



1

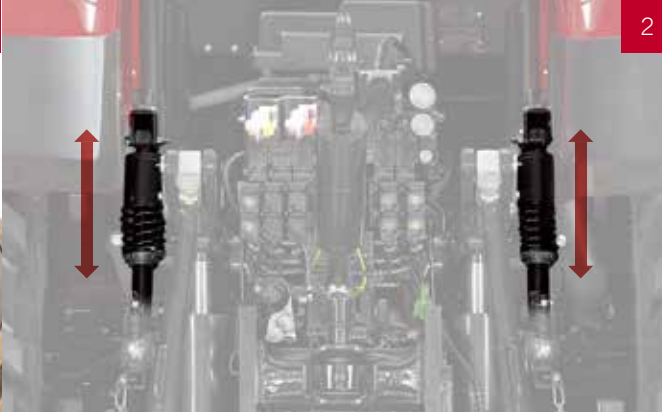

2



3

STAY FRESH ALL DAY LONG

No better way to spend your working day.

- 1 Dual motion driver seat
- 2 Adjustable cab suspension
- 3 Front axle suspension with two damping cylinders and 110 mm travel and 8° oscillation

It is quiet enough inside the cab for you to answer messages on your phone while the AFS™ Accuguide system takes care of steering the tractor more precisely than most drivers can ever hope to manage. In fact, while you are at it, why not connect your phone by bluetooth to the Optum CVXDrive audio system and listen to your playlist?

Well before the headland, the AFS Pro 700™ monitor signals that it is ready to perform the sequence of movements required at the turn. You have excellent visibility of the turning area and the work area behind you – even at night – thanks to the 360° LED lighting package.

The Optum CVXDrive cab offers comfort in abundance with a lightness and freshness that gives you more freedom and flexibility. With new suspension on the front axle, suspension on the front and rear linkages, suspension on the cab and suspension on the driver's seat, the driver is isolated from bumps and jolts but very much in touch with what is happening all around.

The Optum CVXDrive cab designed specifically to help you drive safely on the road and work effectively in the field.

THE OPTUM CVXDRIVE. OPTIMAL COMFORT.

COMFORT ZONE

- Quiet cab only 69 db(A)
- 360° LED light option
- 5.87 m² glass area for best visibility
- Roomy cab with 2.6 m³
- Seat options for a most comfortable ride
- Adjustable cab suspension
- Front axle suspension with adaptive control logic

INTUITIVE OPERATION

You've got every situation under your command.

We know how busy you and your operators are, so we make sure you don't waste time getting used to a new control layout when you switch tractors: in every Case IH tractor, from a Maxxum to a Quadtrac, you will find the same control layout. The Optum CVXDrive control centre is based on the Multicontroller and ICP control panel, which are both integrated into the driver's seat armrest. This means that they are ergonomically placed within easy reach so you literally have the key controls of the tractor at your fingertips at all times.

The Multicontroller lever is neatly configured and backlit so that it is very easy to get to grips with, even if you are using it for the first time. You have a grasp of every situation because

this lever puts all the functions you need in the palm of your hand. Hydraulics, PTO, driveline and lights are operated using the Intuitive Control Panel conveniently situated just in front of the Multicontroller lever. Flowrate pots and timers are located under the flap inside the armrest.

The tractor performance monitor is located in the right-hand A-post and, combined with the AFS Pro 700™ touchscreen monitor, the Optum CVXDrive control layout provides you with a clear overview and real control for safe and stress-free operation.

THE OPTUM CVXDRIVE. OPTIMAL ERGONOMICS.

A





B

- A Tractor- and Performance-Monitor
- B AFS PRO 700™ Touchscreen
- C Multicontroller
- D Remote valve controls incl. joystick
- E ICP – Intuitive control panel
- F Front-/Rear PTO on/off
- G Hydraulic and hitch settings
- H Park lock



C

D

F

H

E

G



POWER TO THE GROUND

Efficiency hour after hour.



Hour after hour in the field, the Optum CVXDrive performs extremely efficiently thanks to our proven FPT-engines and the CVXDrive transmission. In addition the APM Automatic Productivity Management system coordinates engine revs and transmission ratio to ensure optimum efficiency and fuel savings.

THE OPTUM CVXDRIVE. OPTIMAL EFFICIENCY.

OPTUM 300 CVXDRIVE

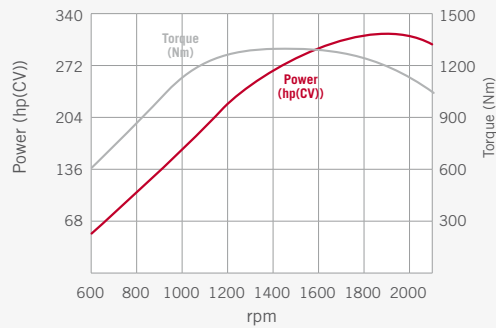

PRODUCTIVE POWER

Designed to be efficient in the toughest conditions.

The Optum CVXDrive is equipped with a new 6-cylinder FPT engine, designed in-house to deliver 250 to 300 rated horsepower smoothly and efficiently. Stage V compliant, the proven Hi-eSCR2 exhaust treatment system lets the engine breathe so it can continuously output top performance while reducing fuel consumption.

What defines a Case IH tractor, is its ability to churn out high torque when the conditions get really tough. As the engine lugs down, the variable geometry turbocharger (eVGT) opens up at lower engine speeds to increase torque, while moving to an extremely efficient setting at higher engine revs.

The cooling system in the Optum CVXDrive works fully independent from engine speed with precise electronic control. To reduce service down-time a variable pitch fan is available. This industry exclusive fan monitors the cooling requirements and quickly adjusts hydraulically the fan blade

angle for best cooling efficiency. Fan blades can be reversed to blow chaff and debris of the front grilles. The cleaning function is storeable in the Headland Management Control II system and cleans the radiator fully automatically.

An industry leading high performance exhaust brake option brings a 40% increase in braking power by including cooling fan and eVGT settings to bring braking efficiency to even higher levels and, at the same time extends the life of front and rear brakes discs.

With its industry leading fuel tank capacity, the Optum CVXDrive can spend all day in the field; something we are sure you and your drivers will be looking forward to, because the power delivered by the Case IH Optum CVXDrive becomes addictive.

THE OPTUM CVXDRIVE. OPTIMAL POWER.

ADVANTAGES

- FPT engine technology from 250 to 300 hp (rated) all Stage V compliant
- Hi-eSCR2 exhaust gas treatment without particle filter
- eVGT turbocharger for a faster engine response and increased torque
- APM Automatic Productivity Management and ECO Drive helps to cut fuel consumption
- 96 litres AdBlue tank
- Industry exclusive variable pitch van option
- 630 litres fuel tank capacity and 96 litres AdBlue tank
- Optional high power exhaust brake

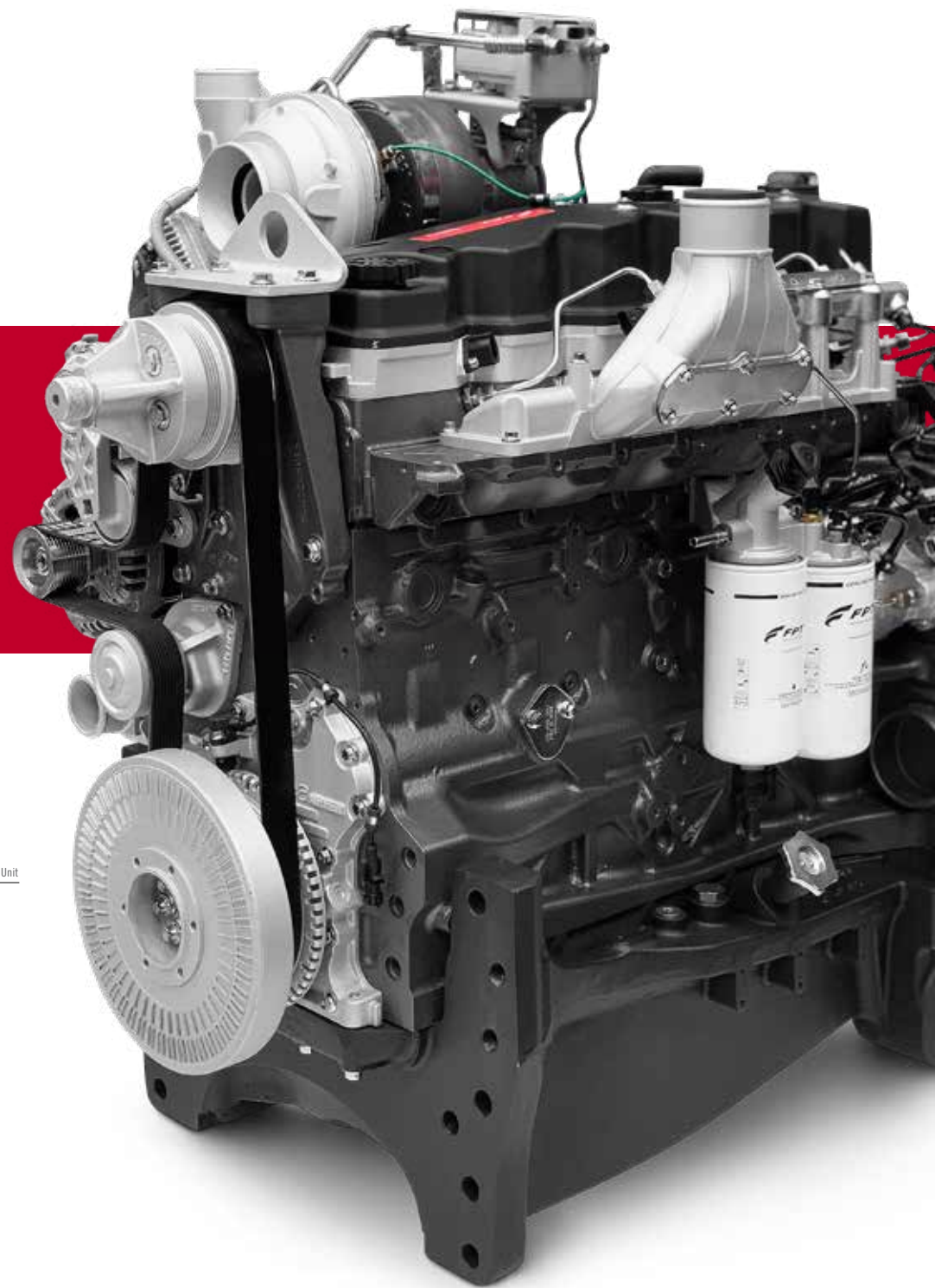

LEGEND

- PM Particulate Matter
- HC unburnt Hydrocarbons
- NO_x Nitrogen Oxides
- CO Carbon Monoxide
- N₂ Nitrogen
- CO₂ Carbon Dioxide
- H₂O Water

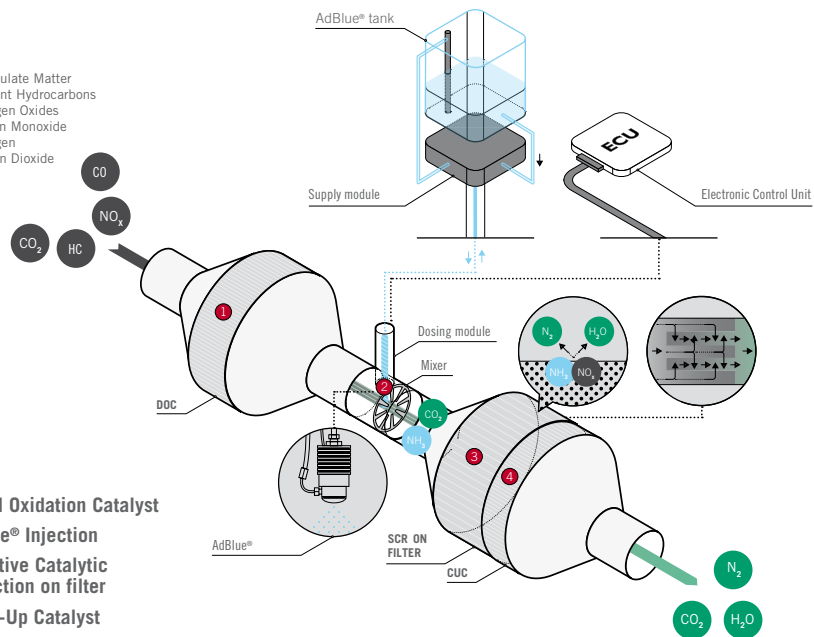

- ❶ Diesel Oxidation Catalyst
- ❷ AdBlue® Injection
- ❸ Selective Catalytic Reduction on filter
- ❹ Clean-Up Catalyst



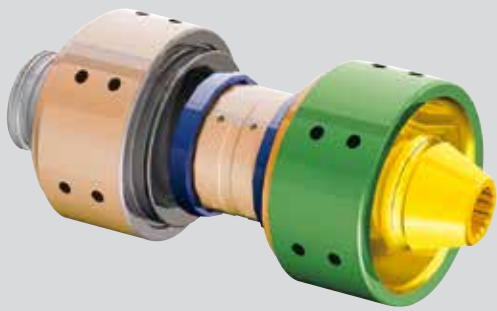

EFFICIENT CVXDRIVE TRANSMISSION

Work your best, always.

CVXDrive continuously variable transmission on Optum CVXDrive – simply the best of working. With seamless range changes between zero and top speed, integrated creeper and just 1600 revs at 50 km/h, the CVXDrive transmission also features Active Hold Control so you can stop and start on hills without using the clutch or brakes.

First implemented on racing cars, it is the DKT (Doppel-Kupplungs-Technologie) Double Clutch Technology that grants the Optum CVXDrive efficient performance. We have not only implemented these clever power transmission systems just because they are efficient, but also because they are easy to use and therefore enhance your operating safety.

THE OPTUM CVXDRIVE. OPTIMAL EFFICIENCY.

ADVANTAGES

- Continuously variable transmission 0 to 50 km/h ECO with fully automatic range change under full draft load
- Efficient DKT™ Double Clutch Technology
- APM Automatic Productivity Management ensures optimum efficiency
- Automatic parking brake
- Active Hold Control holds the tractor with load stationary without applying the brakes
- Sensitive driving with foot pedal and kick-down function for fast response

PRODUCTIVE AND VERSATILE

Built to power any implement.

Versatility and productivity is at the heart of the principles behind Optum CVXDrive. These are tractors capable of handling anything asked of them; compact enough for quick haulage jobs, powerful enough for heavy draft jobs.

In conjunction with the new front and rear axle design, a wheel base below 2,995 mm and 2.15 diameter tyres (e.g. 710/75R42) ensure excellent power to the ground and impressive traction.

THE OPTUM CVXDRIVE. OPTIMAL VERSATILITY.









FOUR-SPEED REAR PTO – TWO-SPEED FRONT PTO

Powerful or economical – the choice is yours.

PTOs are fitted front and rear, with 4 speeds selected electronically as standard on the rear PTO and a 2-speed PTO available to integrate into the front hitch area. The PTOs are operated using the ICP control panel integrated into the driver's armrest.

For jobs with low power requirements, the Optum CVXDrive features 540E/1,000E rpm rear and 1,000E front PTO speed. The Eco speeds are attained at below 1,600 engine rpm which cuts down fuel consumption and noise.

Soft Start works by detecting a higher starting resistance when the PTO is engaged, and steadily increasing the torque load. A

hydraulic brake stops the movement of powered implements as soon as the PTO is switched off. The hydraulically activated and electronically controlled system allows smooth modulation and protects the components.

Automatic PTO management disengages the PTO when the linkage is raised and re-engages it when it's lowered. The position at which the PTO is engaged and disengaged is adjustable and can also be programmed in the new Headland Management Control II.

THE OPTUM CVXDRIVE. OPTIMAL POWER TRANSFER.

ADVANTAGES

- 4-speed PTO standard at the rear
- 2-speed PTO optional at the front
- Front and rear PTO Automatic
- Soft Start PTO takes care of your implements
- Front PTO for greater productivity
- PTO operation can be fully integrated in the Headland Management Control II

	PTO speed	Engine speed [rpm]
4-speed rear PTO	540 / 540 E / 1,000 / 1,000 E	1,930 / 1,598 / 1,853 / 1,583
2-speed front PTO	1,000 / 1,000 E	1,886 / 1,585



VERSATILE CONNECTIONS

Built to handle the heaviest implements.

Case IH has engineered the hydraulic system on the Optum CVXDrive around a powerful pump that has a displacement rating of up to 220 l/min. This gives the front and rear hitch a lift capacity that can handle the heaviest implements effortlessly. This gives you an opportunity to work with larger implements to increase productivity.

The hydraulic pump is designed to produce a high flowrate at low engine revs, so even the highest demand on the spool valves is not going to unsettle the Optum CVXDrive, and at the same time will save fuel.

At the rear, up to 5 electronic remote valves are fitted with simultaneous oil flow rates available on demand that can power the largest machines. These valves are fully configurable using the flowrate and timer controls in the driver's seat armrest. A power beyond unit is also available.

The Optum CVXDrive can be also supplied with mid-mount valves (either 1, 2 or 3) for the front hitch.

Both the rear and front remotes can be operated from the ground using external controls.

Check out the technical specifications. You will be impressed.

THE OPTUM CVXDRIVE. OPTIMAL FLEXIBILITY.

ADVANTAGES

- Maximum rear lift capacity through range of 11,058 kg
- 5 electronic remote valves at the rear and 3 mid mounted are possible
- Up to 220 l/min pump flow for high demand implements
- Fully integrated front linkage with industry leading up to 5,821 kg lift capacity



At a glance overview of flowrate and timer settings on the AFS Pro 700™ monitor.





- 1 4WD and differential lock management.
- 2 Steer-by-ABS and Auto-Steer-by-brake reduces the tractor turning radius.
- 3 Advanced Trailer Brake for enhanced driving stability and safety.

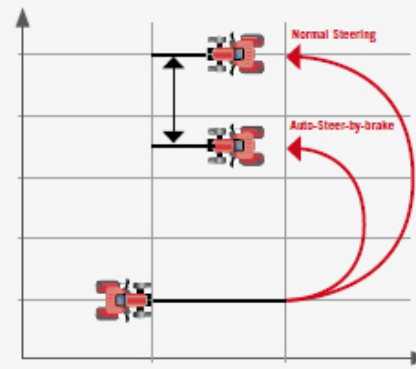

OPTIMAL TRACTION AND ENHANCED SAFETY

Maintain agility – working in the field and braking on the road.

You will discover that the Optum CVXDrive develops impressive tractive power in the field and opens up a completely new range of higher payloads up to 6,300 kg. The front axle features suspension with two cylinders, a brand new reactive steering motor and dual wheel capability. Duals can also be fitted to both rear and front, reducing slip as well as compaction.

This tractor has an impressive turning circle and can be fitted with a wide range of trailer hitches, from the standard automatic trailer hitch up to the ball-type coupling for heavy haulage jobs.

The Optum CVXDrive outputs very high power for its low weight and is capable of travelling at high speed with heavy loads on the road. In addition to enhancing safety, the Case IH Advanced Trailer Brake System is available and will also

provide operators with much greater peace of mind when working with heavy trailed equipment in difficult conditions. As an option, we have equipped the Optum CVXDrive with ABS to provide the best possible braking power – the tractor brakes immediately without skidding, even when hauling heavy trailers, as soon as the driver presses the brake pedal. A tyre pressure monitoring system is also available, which allows the operator to monitor up to 16 tyres either on the tractor or on trailers. The system is integrated within the AFS Pro 700™ monitor and allows the operator to set parameters which, if exceeded, will warn the operator on the display. With airline connection available at the rear of the machine the operator can then re-inflate the tyre to get back to the farm.

THE OPTUM CVXDRIVE. OPTIMAL SAFETY.

ADVANTAGES

- 4WD and differential lock management
- Turning radius of just 7.7 m
- Front axle suspension increases stability and traction
- Advanced Trailer Brake System improves tractor stability and safety
- ABS Anti-Lock Braking System to stop quickly and confidently
- Auto-Steer-by-brake (ABS advanced)
- Tyre pressure monitor system to keep optimal traction
- Up to 2,000 kg front ballast or rear wheel ballast up to 1,182 kg
- Versatile tyre offering up to 2.15 m diameter



STAY ON THE RIGHT TRACK

Case IH Advanced Farming Systems (AFS™) for top efficiency.



What adds to the great feeling of owning and driving Case IH's latest tractor is knowing that the Optum CVXDrive is an intelligent investment. This is underlined by value-adding features such as the latest Advanced Farming System (AFS™), full ISOBUS compatibility and the HMC II headland management system.

We have designed our AFS™ concept to optimise your operating costs and make driving long days in the field an enjoyable, stress-free experience.

ISOBUS compatibility goes without saying on this class of tractor and controls on the Optum CVXDrive's touchscreen monitor are the best you will experience.

Likewise, we have enabled the headland management system (HMC II) to automate more and more of the tractor's operations.

THE OPTUM CVXDRIVE. OPTIMAL PROFITABILITY.

- 1 AFS AccuGuide: GPS and GLONASS based guidance
- 2 xFill bridges RTK⁺ signal gaps of up to 20 minutes
- 3 Monitor and manage your machines with AFS Connect™ Telematics



AFSUPPORTCENTER

0 800 0281 910
afssupporteur@caseih.com

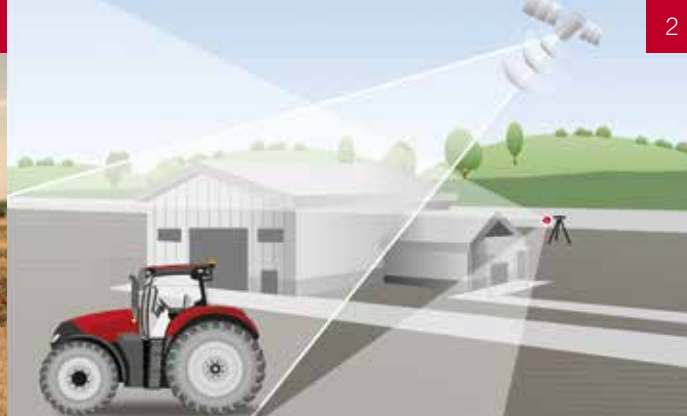

TRUE SENSE OF DIRECTION

Step up the way you work with Advanced Farming Systems.

Case IH Advanced Farming Systems (AFS™) have been at the forefront of precision farming for more than a decade. Case IH AFS tools include everything you need to achieve repeatable accuracy, reduce overlaps, cut input costs and maximise your profitability.

Optum CVXDrive tractors are available „AFS™ Accuguide ready“ and fitted with an AFS Pro 700™ touchscreen monitor. This means that your dealer can pre-install a fully automatic, integrated GPS/GLONASS guidance system to give you industry-leading precision in the field. Add a local RTK+ signal station and it points you directly to 1.5 cm pass-on-pass accuracy. Don't worry about line-of-sight signal reception; our software features the xFill app that bridges the

RTK+ system for up to 20 minutes so the AFS system keeps its sense of direction even in the shadow of trees etc.

The optional Case IH AFS Connect™ telematics system allows farm owners and managers to monitor and manage their machinery from the farm office. They can track machines in real time on the farm computer to observe how the machines are performing through the use of precision guidance GPS signals and wireless data networks. Analysing the data it provides helps to improve logistics, minimise fuel consumption and maximise performance.

THE OPTUM CVXDRIVE. OPTIMAL GUIDANCE.

ADVANTAGES

- Range of signal accuracies available
- Receivers use both GPS and GLONASS signals
- Low cost RTX signal solution
- Optional high accuracy RTK+ signal with accuracy levels down to 1.5 cm
- Integrated AccuGuide auto-guidance for Optum CVXDrive
- xFill bridges RTK+ signal gaps of up to 20 minutes
- AFS Connect telematics provides machine tracking and performance data

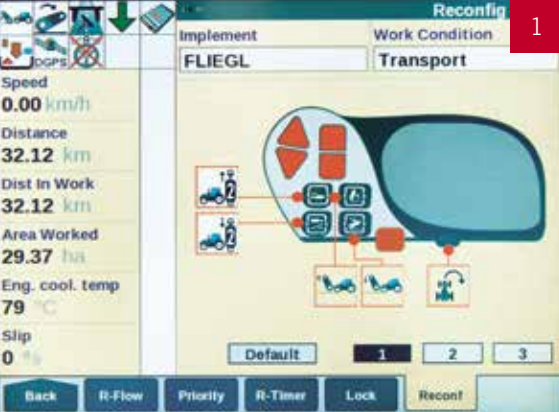

- 1 Individually configure the lever to the remote valve
- 2 Performance monitoring.
- 3 Monitor your equipment with video cameras

PRECISE CONTROL

Interactive, integrated and intuitive.

Benefit from the full capabilities of the Case IH AFS Pro 700™ touchscreen monitor, providing complete in-flight productivity management. Integrated into the driver's seat armrest, this touchscreen monitor gives the driver complete control over all the tractor's automated function sequences while providing on-the-move feedback on running costs and yield.

It is easy to set up the tractor using the intuitive AFS Pro 700™ software to communicate directly with the relevant AFS auto-guidance system and synchronise systems with other ISOBUS-compatible machinery. You can also programme and adjust hydraulic flowrates and timers, memorise standardised headland sequences and connect rear-view video cameras.

Once everything is set up, two key features that drivers will be using in the field are the AFS guidance tools and the implement screens, which are displayed automatically on the monitor as soon as front and rear ISOBUS-compatible machines are connected. Now you have full control over the machinery, including time and distance based headland management features, using the touchscreen.

The monitor also provides feedback on productivity and fuel consumption, which you can transmit automatically to your farm PC or save to an external USB drive. The Optum CVXDrive is your go-to productivity professional.

THE OPTUM CVXDRIVE. OPTIMAL CONTROL.

ADVANTAGES

- Intuitive AFS Pro 700™ touch screen
- Improved productivity with up-to-the-minute information
- Split screen compatible for those who like to install a second AFS Pro 700 monitor on the baler bar
- AccuTurn Pro™: automatic turning
- Individually configure remote valves on the Multicontroller lever
- Keep an eye on areas which you can't see from the driver seat with optional video cameras
- Get instant messages from AFS Connect™.





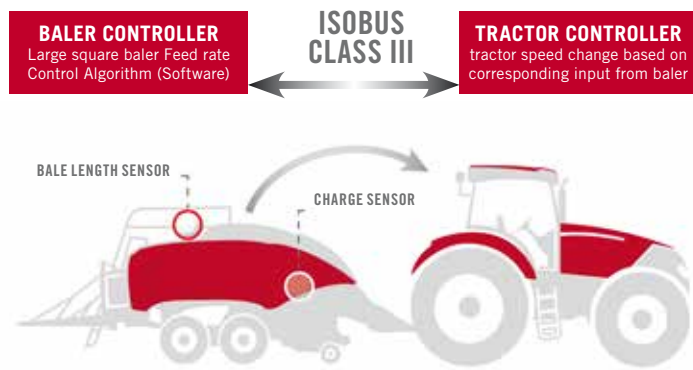
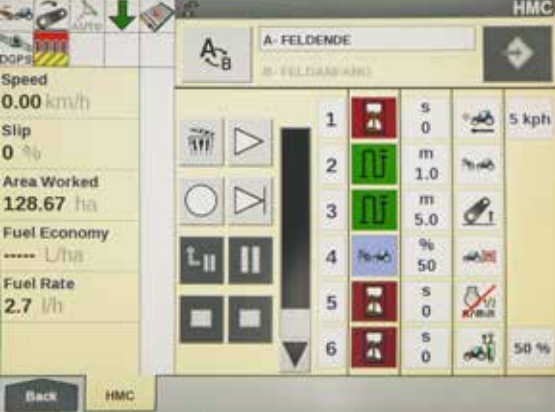

THE PRODUCTIVITY PROFESSIONALS

Headland Management Control II and AccuTurn Pro plus integrated ISOBUS compatibility.

Optum CVXDrive models feature Headland Management Control II, which is designed to assist the driver when turning at the headland. Each step can be programmed either by time or distance travelled. In addition, certain triggers for various other automated functions can be set, such as lowering the engine speed after lifting the implement. A headland sequence can be taken while driving or programmed on the stand. Playback of the headland sequence can be automatically or manually run, and can be accessed via the Multicontroller, the AFS Pro 700™ monitor or the ICP (Intregrated Control Panel) on the armrest. In contrast to ISOBUS I and II, where the AFS Pro 700™ monitor indicates settings of the implement and controls implements with ISOBUS II, with ISOBUS III is it possible

for the implement to control the Optum CVXDrive. The tractor will automatically adjust forward speed, steering (option), hitch position and PTO speed, as well as operating remote valves depending on the implement. The result is optimum efficiency of the implement and tractor.

And now, with new AFS AccuTurn Pro technology, headland management and steering processes are combined, automating the entire headland operation, calculating the optimum turning path and speed and controlling the implement, for even greater efficiency and comfort.

THE OPTUM CVXDRIVE. OPTIMAL AUTOMATISATION.

ADVANTAGES

- Headland Management Control II automates workflows for less driver fatigue and higher productivity.
- ISOBUS II Watch and control implement settings with the AFS Pro 700™ monitor.
- ISOBUS III for best efficiency; the attached implement controls, for example, tractor speed, steering (option), hitch raise/lower and PTO speed.
- AccuTurn Pro combines automatic steering and headland turning functions for complete automation.

8 YEARS IN A ROW
INDUSTRY LEADER



2018 MARKS THE 8TH CONSECUTIVE YEAR THAT CNH INDUSTRIAL IS A CONFIRMED INDUSTRY LEADER IN THE PRESTIGIOUS DOW JONES SUSTAINABILITY INDICES WORLD AND EUROPE.





REDUCE THE CONSUMPTION OF RESOURCES BY MOVING FROM FOSSIL FUELS TO A **A RENEWABLE ENERGY SYSTEM**



INCREASE AGRICULTURAL PRODUCTIVITY TO **IMPROVE FOOD AVAILABILITY**



REDUCE **ENVIRONMENTAL IMPACT** AND OPTIMIZE **ENERGY CONSUMPTION** IN ALL COMPANY PROCESSES



INCREASE OPPORTUNITIES FOR EXCHANGING **IDEAS** AND **GOOD PRACTICES** WITH ALL **STAKEHOLDERS**

SUSTAINABILITY

It's part of everything we do

Case IH is part of CNH Industrial, one of the world's largest capital goods companies. It has a firm focus on its environmental responsibilities, and has been a seven-time leader in the Dow Jones Sustainability Index. Within the CNH Industrial group:

- 91% of waste is recovered
- 27.5% of water used is recycled and
- 56% of electricity used is from renewable sources.

Being a global leader in capital goods carries great responsibilities, which means that we must be accountable for every global activity we perform. Our responsibility does not stop at the factory gate, and we have made great efforts to be proactive when it comes to the broader global issues surrounding sustainability.

Over the years, our work in research and development has been geared towards ensuring that our products continue to achieve increasingly high standards in terms of safety and eco-compati-

bility. Rather than limiting customers to a choice between low operating costs and eco-efficiency, our strategy is to offer products that deliver both.

By providing innovative products and solutions that abide by environmentally responsible operating practices, Case IH is doing its part to address global issues such as climate change. Today's companies face complex and interconnected challenges that demand an ever-evolving approach to sustainability, a scenario that Case IH believes is an important driver in creating long-term value for all its stakeholders, which is a core objective of the brand.

At Case IH, our engineers are focused on producing machines that not only work on the land, but work with it too.

CASE IH. ALWAYS FUTURE-FOCUSED.

THE SUSTAINABILITY GROWTH DRIVERS ARE:

- Necessity to feed an increasing population
- Importance of soil protection for future generations
- Growing sustainable farming solutions
- Increasing public awareness
- Fostering people engagement



KEEP FARMING

Servicing made simple.

We know that in this business time is critical and the less time you need to spend on servicing the better. Daily checks and routine maintenance on a Case IH Optum CVXDrive are straightforward and convenient. Simply perform your standard checks and your Optum CVXDrive is ready for action.

We have designed Optum CVXDrive tractors for extended 750-hour service intervals to keep your maintenance costs down and keep you farming.

THE OPTUM CVXDRIVE. OPTIMAL SERVICING.

ADVANTAGES

- Unrivaled 750 hour maintenance intervals for engine and 1,500 hours for transmission and hydraulics
- Maintenance free Hi-eSCR2 after treatment system
- No exhaust gas recirculation
- Easy access for fast daily checks
- Reversible fan cleans cooling packages automatically to reduce service downtime
- Airline connection (optional) at the rear for in-field cleaning
- Industry leading 630 litres fuel tank capacity and 96 litres AdBlue tank for a longer working day







BE A FARMER, WE TAKE CARE OF THE REST

ServiceTeam

The Case IH **SERVICETEAM**, a strong dealer network backed up by local Case IH market teams, industry leading Case IH supporting tools, modern training methods, best in class spare parts support and logistics performance providing Case IH customers with an excellent all-encompassing after-sales service, keeping customers farming!

TECHNICAL SUPPORT | SERVICE | PARTS | MAXSERVICE | SERVICEFINANCE

GENUINEPARTS WE KEEP YOUR EQUIPMENT RUNNING.

Your local Case IH dealer and our dedicated 24/7 parts call centre technicians and their logistic colleagues are all part of the Case IH ServiceTeam network. They're highly trained to give you expert advice and solve problems, ensuring the correct, genuine Case IH parts are located and dispatched right away, reaching you next day or sooner to keep your machine in top condition.

MAXSERVICE AROUND THE CLOCK. AROUND THE COUNTRY.

When you're working around the clock, MaxService ensures you're never alone. It's a dedicated helpline that connects you to the Case IH ServiceTeam 24/7. Call technicians at your local dealer are ready to assist with technical advice, software solutions and genuine parts ordering. At peak season, we can keep you farming with breakdown assistance.

SAFEGUARD GOLD

SAFEGUARD SILBER

SAFEGUARD BRONZE

SAFEGUARD GOLD, SILVER OR BRONZE, IS AN EXTENDED WARRANTY SERVICE PACKAGE.

Specifically tailored around you and your machinery, it can include maintenance contracts, servicing, telematics, insurance and Case IH finance packages. Most importantly, it provides peace of mind, mechanical coverage and makes the cost of ownership clear and easy to manage.



AN OPTIMAL FINANCING SOLUTION FOR EVERY INVESTMENT.

CNH Industrial Capital is the financing company for Case IH. Our employees are financial experts and have many years of experience in agriculture. We do not only know about Case IH products and the market, we also understand the individual requirements of your operations. Therefore we are always able to offer you a financial solution for your new investments that is tailored specifically to your operational requirements. Our most important goal is improving the profitability of your investments!



MODELS	OPTUM 250 CVXDRIVE	OPTUM 270 CVXDRIVE	OPTUM 300 CVXDRIVE
ENGINE	FPT	FPT	FPT
Number of cylinders	6	6	6
Type	Common Rail Diesel engine with 24 valves, eVGT single turbocharger and Hi-eSCR2 only exhaust after treatment		
Emission level	Stage V	Stage V	Stage V
Capacity (cm ³)	6,728	6,728	6,728
Maximum power ECE R120 ³⁾ (kW/hp(CV))	201 / 273	212 / 288	230 / 313
... at engine speed (rpm)	1,800	1,800	1,800
Rated power ECE R120 ³⁾ (kW/hp(CV))	184 / 250	199 / 271	221 / 300
... at engine speed (rpm)	2,100	2,100	2,100
Maximum torque (Nm @ 1,400 rpm)	1,173	1,194	1,282
Torque rise (%)	40	32	28
Fuel tank, diesel / urea (litres)	410 / 96	630 / 96	630 / 96
TRANSMISSION			
CVXDrive - continuously variable transmission 50km/h ECO or 40km/h ECO	●	●	●
Powershuttle	●	●	●
Rear axle diff-lock type	Multi disc wet plate with management system		
Service brake	Hydraulically operated multiple wet disc brake, self adjusting		
POWER TAKE OFF			
Type	Electro-hydraulic with Auto PTO control available		
Speeds	540 / 540E / 1,000 / 1,000E		
... at engine speeds (rpm)	1,930 / 1,598 / 1,853 / 1,583		
Shaft type Standard (Option)	1 3/8" 21 splines (1 3/8" 6 splines, 1 3/4" 20 splines)		
FRONT PTO AND FRONT HITCH	○	○	○
Speeds	1,000 / 1,000E	1,000 / 1,000E	1,000 / 1,000E
... at engine speeds (rpm)	1,886 / 1,585	1,886 / 1,585	1,886 / 1,585
Max. lift capacity (kg)	5,821	5,821	5,821
OECD lift capacity through range @ 610 mm (kg)	4,487	4,487	4,487
FOUR-WHEEL DRIVE AND STEERING (DRIVELINE)			
Type	Electro-hydraulic with management system, electro-hydraulic differential lock and active front suspension system standard		
ABS Anti-lock braking system	○	○	●
Front axle suspension	●	●	●
Steering angle (°)	55	55	55
Min. turning radius ³⁾ track setting 1,930mm (m)	7.7	7.7	7.7
HYDRAULIC SYSTEM			
System type	Variable displacement, pressure flow compensated pump		
Max. pump flow rate Standard / Optional (l/min)	165 / -	165 / 220	165 / 220
System pressure (bar)	215	215	215
Control type	Electronic Hitch Control (EHC) with cushion ride control		
Max. lift capacity through range [kg]	11,058	11,058	11,058
OECD lift capacity through range @ 610 mm (kg)	10,305	10,305	10,305
Max. number of rear remote valves	5 electronic		
Max. number of mid mount valves with electronic joystick	3 electronic		
Remote valve timer control	1 - 60 seconds on all models		
Category type	Cat III N	Cat III / IVN	Cat III / IVN
Slip control	●	●	●

MODELS	OPTUM 250 CVXDRIVE	OPTUM 270 CVXDRIVE	OPTUM 300 CVXDRIVE
WEIGHT			
Approximate shipping weight (kg)	10,500	10,500	10,500
Permissible total weight (kg)	16,800	16,800	16,800
Max. permissible weight front single / dual wheels (kg)	7,500 / 6,500	7,500 / 6,500	7,500 / 6,500
Max. permissible weight rear (kg)	11,600	11,600	11,600
DIMENSIONS			
A: Max. length with front and rear lower links down (mm)	5,700	5,700	5,700
B: Total height (mm)	3,265	3,265	3,265
C: Minimum width across rear tyres (min./max.) (mm)	2,536 / 2,993	2,536 / 2,993	2,536 / 2,993
D: Wheel base (mm)	2,995	2,995	2,995
E: Height at centre of rear axle, highest point (susp.cab) (mm)	2,341	2,341	2,341
F: Track setting front (mm)	1,858 - 2,258	1,858 - 2,258	1,858 - 2,258
rear (mm)	Bar axle: 1,840 - 2,374	Bar axle: 1,840 - 2,374	Bar axle: 1,840 - 2,374
STANDARD TYRES ²⁾			
Front	540 / 65 R28	540 / 65 R28	540 / 65 R30
Rear	650 / 85 R38	650 / 85 R38	650 / 65 R42
BIGGEST TYRE COMBINATIONS AVAILABLE			
	GROUP 48	GROUP 49	GROUP 49
Front	600 / 70 R30, IF 600 / 70 R 30	650 / 60 R34, IF 620 / 75 R 30 (IF 650 / 60 R 34) ⁴⁾	650 / 60 R34, IF 620 / 75 R 30 (IF 650 / 60 R 34) ⁴⁾
Rear	710 / 70 R42, 800 / 70 R 38 IF 710 / 70 R 42, IF 800 / 70 R 38 ⁴⁾	710 / 75 R42, 900 / 60 R 42 IF 710 / 75 R 42, IF 900 / 60 R 42 ⁴⁾	710 / 75 R42, 900 / 60 R 42 IF 710 / 75 R 42, IF 900 / 60 R 42 ⁴⁾

● Standard Equipment ○ Optional Equipment ¹⁾ With standard tyres ²⁾ Other tyres on request ³⁾ ECE R120 correspond to ISO 14396 and 97 / 68 / EC ⁴⁾ IF = Improved Flexion ==> up to 20 more load capacity at identical air pressure

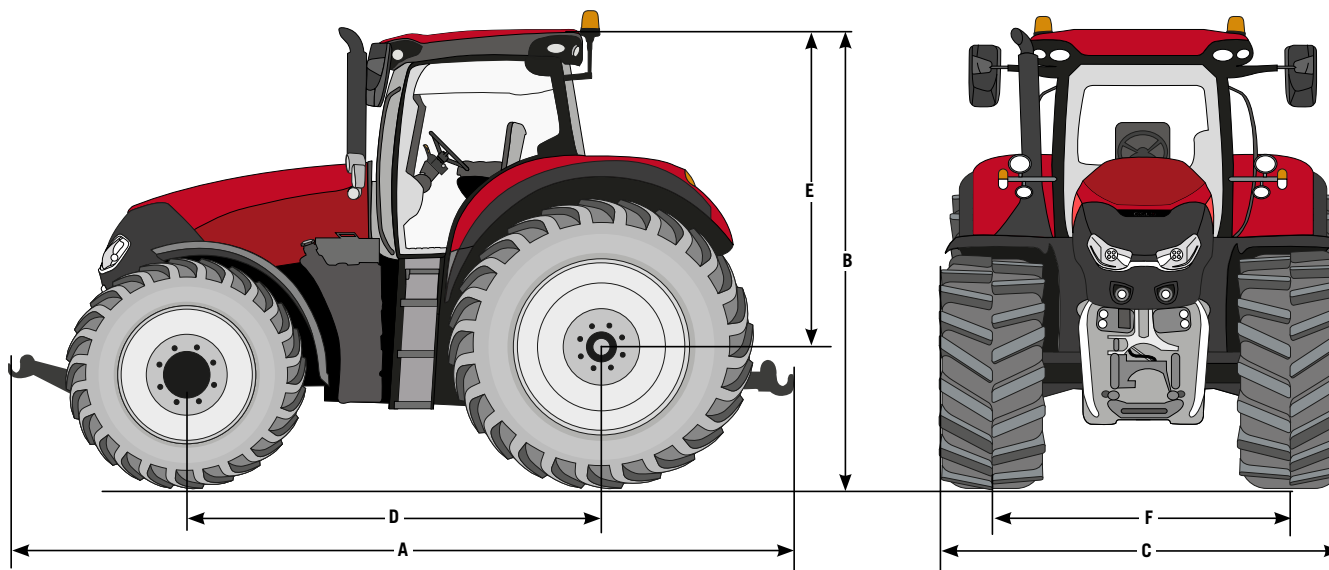

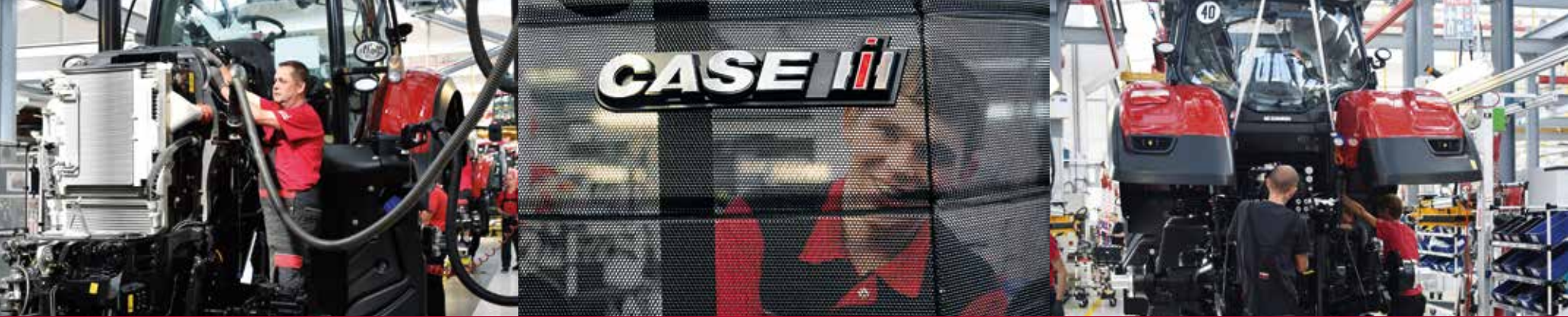

MADE IN AUSTRIA

Built with passion.

Every Case IH Optum CVXDrive tractor carries the flag for Austrian engineering and manufacturing excellence. Home to the Case IH European headquarters, the St Valentin plant relies on the passion and expertise of our engineers and production workers, as well as state-of-the-art assembly lines to produce tractors ranging from 86 to 300 hp with the highest quality and precision.

Ninety percent of tractors produced here are exported, carrying our culture of excellence around the world. The CNH Industrial tractor plant in St. Valentin, Austria, performs

impressively in the annual World Class Manufacturing (WCM) audit, a success that is attributed to world-class production and highly-qualified employees. WCM stands for competence, quality and performance of enthusiastic staff.

Processes are optimised and testing as well as quality controls follow strict regulations that go far beyond recognised industry standards. Our clear focus is to deliver machines that are ideal for leading farming businesses and contractors.

CNH Industrial Österreich GmbH
Steyrer Straße 32, A-4300 St. Valentin – Austria

Free phone: 00 800 22 73 44 00

 Safety never hurts! Always read the Operator's Manual before working with any equipment. Inspect equipment before using it, and be sure it is operating properly. Follow the product safety signs, and use any safety features provided. This literature has been published for worldwide circulation. The standard and optional equipment and the availability of individual models may vary from one country to the next. Case IH reserves the right to undertake modifications without prior notice to the design and technical equipment at all times without this resulting in any obligation whatsoever to make such modifications to units already sold. Whilst every effort is made to ensure that the specifications, descriptions and illustrations in this brochure are correct at the time of going to press, these are also subject to change without prior notice. Illustrations may show optional equipment or may not show all standard equipment. Case IH recommends **AKCELA** lubricants.

